

- KDT-1000A KDT-1000W KDT-1000N
- KYT-1000A KYT-1000W KYT-1000N



K-1000 Ice Kube Machine



- Easy access to food zone with removal of two screws and lift-off door
- High-tech exterior with smudge and fingerprint resistant stainless-like finish
- White plastics in the food zone help identify areas needing cleaning
- Water shield, distribution tube, pump, floats, and trough removable by hand
- Available CleanAir™ pack controls the growth of bacteria and fungi that form slime and cause odors in the food zone

WARRANTY:

Ice Maker: 3 year Parts & Labor
 Evaporator: 5 year Parts & Labor
 Compressor: 5 year Parts & 3 year Labor



HALF KUBE
 $\frac{3}{8}'' \times 1\frac{1}{8}'' \times \frac{7}{8}''$
 (.95 x 2.86 x 2.22 cm)

= 100%



KUBE
 $\frac{7}{8}'' \times \frac{7}{8}'' \times \frac{7}{8}''$
 (2.22 x 2.22 x 2.22 cm)

= 100%

Refrigerant R410A



K-1000
ICE KUBE MACHINE

Koolaire K-1000 Ice Kube Machine on a K570 bin.

Both ice machine and bin are AHRI certified.



By MANITOWOC

2110 SOUTH 26TH ST | MANITOWOC, WI 54220 USA | 1-920-682-0161 | www.kool-aire.com



K-1000 ICE KUBE MACHINE

| Model | Icon | Icon | 24h | | [kWh/100 lbs ice] | [gal/100 lbs ice] |
|------------|------|------|----------------------|----------------------|-------------------|-------------------|
| | | | 70°/50°F 21°/10°C | 90°/70°F 32°/21°C | | |
| KDT-1000A | | | 890 lbs | 680 lbs | 5.35 | 20.0 |
| | | | 404 kg | 308 kg | | |
| KYT-1000A | | | 960 lbs | 775 lbs | 4.9 | 20.0 |
| | | | 435 kg | 362 kg | | |
| KDT-1000W | | | 835 lbs | 720 lbs | 4.35 | 20.0 |
| | | | 379 kg | 327 kg | | |
| KYT-1000W | | | 860 lbs | 730 lbs | 4.25 | 20.0 |
| | | | 390 kg | 331 kg | | |
| KDT-1000N* | | | 850 lbs | 700 lbs | 5.3 | 20.0 |
| | | | 386 kg | 318 kg | | |
| KYT-1000N* | | | 930 lbs | 760 lbs | 5.2 | 20.0 |
| | | | 422 kg | 345 kg | | |

* Remote condenser JCT1200 must be ordered with "N" models

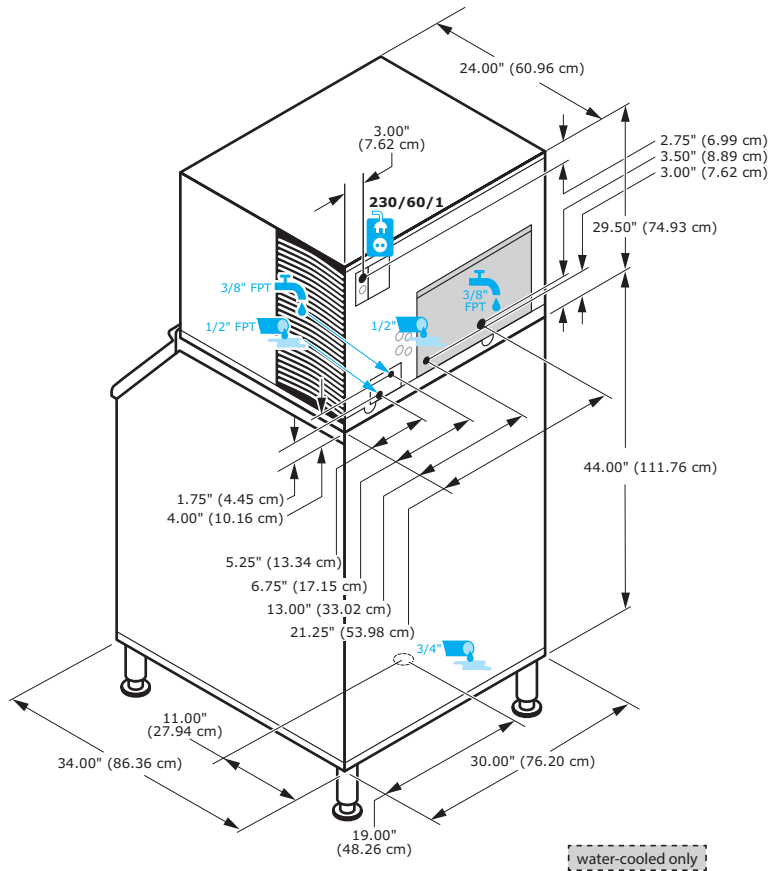

| Minimum | Maximum |
|-------------------------------|--------------------------|
| 40°F 4.4°C | 110°F 43.3°C |
| 40°F 4.4°C | 90°F 32.2°C |
| 20psi 138 kPa | 80psi 551 kPa |
| 10.8 10.1 9.8 | A |
| | 15 Amps |
| 215 lbs 215 lbs 237 lbs | 97 kg 97 kg 108 kg |

Water cooled condenser water usage/ 100lbs or 45.4kgs. of ice: 140 gals/530 L.

| Popular Accessories | | | |
|---|---|----------------------------------|---------------------------|
| Artic Pure Water Filters AR-Pre & AR 20000 | Dispenser Bin Thermostat Kit K-00457 | Top Air Discharge Kit K-00449 | Clean Air Pack K-00206 |

KOOLAIRE

By MANITOWOC

2110 SOUTH 26TH ST | MANITOWOC, WI 54220 USA | 1-920-682-0161 [www.kool-aire.com]